

Student: Tessa Oliaro

Professor: Garrett Brown, MPH, CIH

Major Project: The Perils of ‘Dancing Work’ in Sri Lanka

7 December 2018

Clean Clothes Campaign



A. Kaizen

Introduced by Japan, Sri Lanka now operates with a kaizen mentality by thriving upon productivity, efficiency, and earnings. Through this window there is no mention or adoption of safe practices that revolve around health and safety. Sri Lanka manufacturers have adopted a new approach to sewing operations in their factories, called ‘dancing work’. Kaizen is a Japanese style workplace structure that thrives upon continuous incremental improvement. A cooperative environment is needed to overcome daily struggles in the workplace. The key ideas behind a kaizen process are: perceptiveness, which is based on being able to identify workplace problems, idea development, which is based on

developing focus teams to come up with innovative ideas, and decision, implementation, and progress, which is based on the focus teams’ evaluation of the progress after the decision and implementation of a new solution has been put into practice. The picture below outlines the Kaizen process.

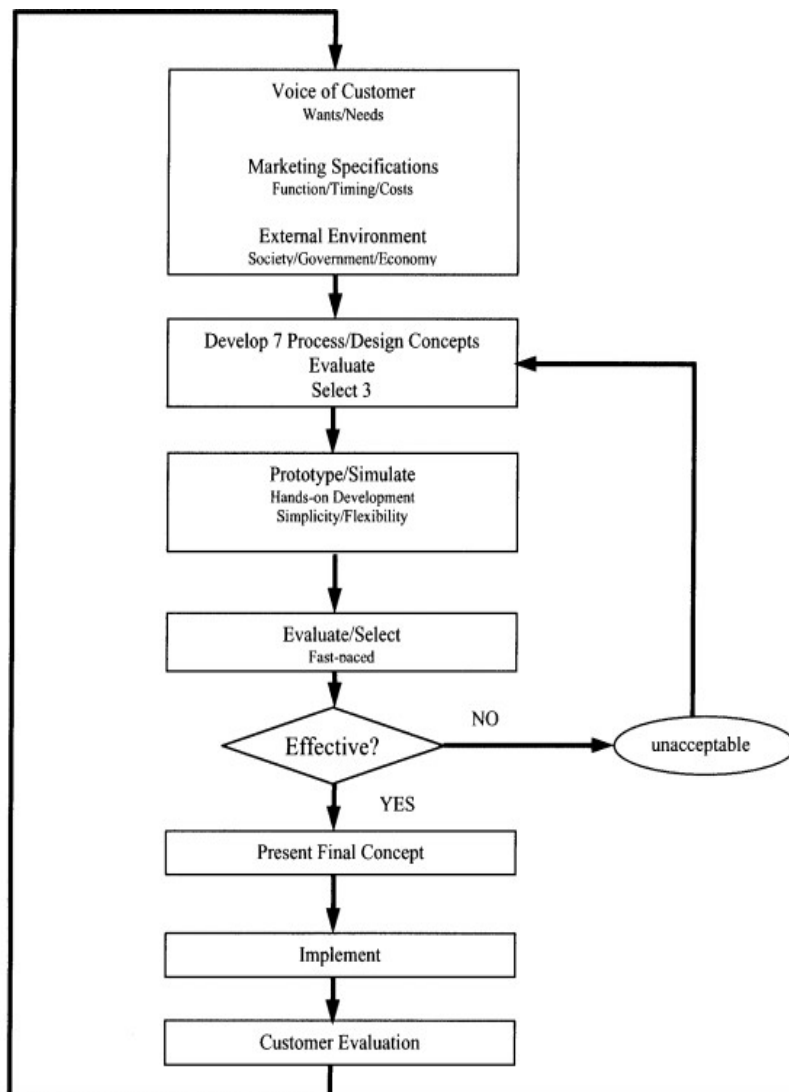

Figure 1: The basic outline structure of the Japanese Kaizen mentality (Chem, 2001).

B. Cellular

Cellular manufacturing is a system where each worker is divided into a production sub-cells. In each sub-cell, a worker typically completes three processes on several different machines, until the product is passed to the next sub-cell. During the work processes the employee is standing and moving around in a circle to use each machine. Labor division allows for the operators to have low comprehensive labor skills and be specifically trained in a limited number of processes. There is less investment on equipment. There is a buffer zone in order to balance the production demands if one operator sub-cell is performing too quickly or too slowly in relation to the rest of the production line (Pan, 2014).

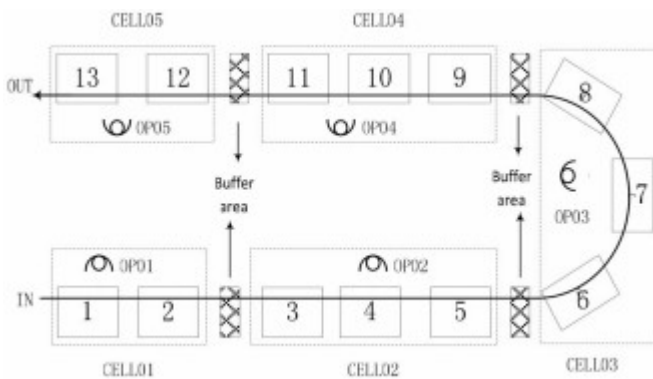

Figure 2: The sub-cell cellular manufacturing operation has one operator working on a select number of processes and rotating from each station within his/her respective sub-cell.

C. The Impact and Breadth of the System

This system came to Sri Lanka factories because of the documented negative health effects of sitting for long periods of time. According to OSH staff in Sri Lanka, they believe that the ILO says that standing for long periods of time is not a health issue but sitting is a problem. Therefore, employers decided it would be cost effective and beneficial to the health of the employees to lift the Juki sewing machines, so that operators could sew while standing. This system was coined ‘dancing work’ because employees would stand and move from machine to machine. This is outlined with a graphic in Appendix A. Although there are less documented health issues and impacts with the ‘dancing work’ system, women would still be returning from work with unbearable leg and back pain. Some women were hardly able to stand.

It is evident that there are negative health impacts, specifically ergonomic, with this ‘dancing work’ or cellular manufacturing system. These impacts are costing women their jobs and their health. Now, thousands of vacancies, nearly 7,400 have opened in Sri Lanka factories because the turnover rate for employees is so high. This system has been used in large manufacturing countries such as Japan, Europe, and America (Pan, 2014). Highly profitable companies such as Lee Apparel Co., The Arrow Co., Jaymar-Ruby Group, Woolrich, Jostens Graduation Russell Corporation, J.P. Hammill, OshKosh B’Gosh, and J.L. Miller & Son have also implemented this system.

The Problem

A. Lean Production

In Sri Lanka, employers and manufacturers have resolved to cutting the number of employees, but not cutting down the respectful workload. This concept is also known as lean production. Lean production is an all-encompassing model with elements of Kaizen, or Japanese style production ideas (Landsbergis, 1999). Although lean production is not the exact same as modular or cellular manufacturing, the risks for job stress and ergonomic hazards persist. Lean production was designed to improve productivity, quality and profitability for companies, but did not consider occupational injuries and illnesses due to job strain. Lean production also does little to empower workers, as the workers are

		Psychological Job Demands (Demand)	
		Low	High
Decision Latitude (Control)	Low	Passive	High Strain
	High	Low Strain	Active

stuck between the quadrant of low decision latitude and high job demand:

Figure 3: This job strain model outlines how lack of control within a workplace and lack of decision

ability can lead to high job strain (Ahmad, 2016).

Low decision latitude and low psychological demand can lead to passivity in the workplace. Whereas high decision latitude and high psychological job demand, can lead to active learning and a desire to develop new productive behavior patterns. Job strain is the combination of high psychological demand and low decision latitude (Landsbergis, 1999).

Lean production also creates an intensified workplace environment and an increase in demand from a smaller workforce. Jobs with increased job strain and ergonomic stress tend to be the most susceptible to musculoskeletal disorders (MSD). A study by the Cornell Worksite Blood Pressure group, showed that men in a high job strain environment for over 3 years had 10mm Hg higher systolic blood pressure compared to men that were not in a high job strain environment (Schnall 1998). Although it is argued that workers within a lean production system have the freedom to control their own work, the stress is far too much to outweigh this proposed benefit. This system, which was originally based on interviews with managers, did not consider the occupational health risks placed on workers (Womack, 1990). Workers are expected to perform more tasks at a faster rate with less employees. This highlights the critical need for unions in Sri Lanka order to lobby for occupational health and protection.

The Health Effects

A. Low Back Pain

A study done Nelson-Wong in 2008, stated that prolonged standing can result in a significant increase in the co-activity of the different gluteus muscles, specifically the gluteus medius. This muscle is a part of a muscle group that stabilizes the pelvis while standing “by abducting, medially rotating, and laterally rotating the thigh at the hip” (Waters, 2015) As a result, too much movement while standing during ‘dancing work’, could lead to the overuse and eventual injury of these gluteus muscles (Waters, 2015). Another study done by Claus in 2008, compared differences between sitting and standing work,

and the effects on intradiscal pressure. The study found there is more intradiscal pressure during standing versus sitting. This is important because intradiscal pressure can cause disc degeneration and a higher incidence of low back pain. Therefore, this study found that sitting was not worse than standing when comparing disc degeneration and low back pain (Karakolis, 2016). It is evident through various studies that prolonged standing can have negative health consequences, including low back pain.

B. Cardiovascular

Another major health impact of prolonged standing is negative cardiovascular outcomes. A study done by McCulloch in 2002, confirmed that standing for more than 8 hours causes an increased incidence in CVI, or chronic venous insufficiency, for workers. CVI is a precursor to more serious cardiovascular health outcomes (Waters, 2015). Another study conducted by Sudol-Szopinska in 2007, examined the impact for workers of prolonged standing and the risk of chronic venous disorders (CVD) compared to workers who primarily sat for the duration of the work day. The results showed that prolonged standing increased the risk of CVD symptoms in workers (Waters, 2015). Prolonged standing is documented through extensive research to have negative cardiovascular health impacts.

C. Fatigue

Another health impact associated with occupational prolonged standing is fatigue. Although discomfort is typically measured by a subjective means, physical fatigue can be quantified with biomechanical measures including postural stability force platforms, muscle electromyography, and muscle surface temperature. In a paper by Waters in 2015, it was found that four studies of prolonged workplace standing tasks, were associated with fatigue and discomfort (Waters, 2015). This is relevant to the Sri Lanka factories as the women are experience a high incidence of fatigue by the end of the workday.

D. Impacts on Pregnancy

Prolonged standing can also lead to adverse birth outcomes such as stillbirths, spontaneous abortions, low birth weight, and preterm deliveries. A study by Teitelman in 1990, observed maternal workload, particularly prolonged standing, and the impact on preterm births and low birth weight. It was found that prolonged standing while working is indeed significantly associated only with increased preterm births (Waters, 2015). This is important because many women in the workplace in Sri Lanka are young and are primarily working to build a dowry in hopes of getting married. This impact could significantly alter their lifelong ability to be a mother. Another study by Paul in 1994, evaluated pregnant women in the workplace, and their postural changes throughout the day. The results from the study indicated that pregnant women would “stand further from the table, with hips positioned more backwards with increased trunk flexion and with arms more extended” (Waters, 2015). This is important because if the ‘dancing work’ relies on lifted tables, pregnant women will be in detrimental postural positions throughout the workday, which could impact their ability to give birth. Consistent standing work is known to cause sore feet, leg swelling, varicose veins, muscle fatigue, low back pain, neck and shoulder stiffness, and other health problems.

Solutions

The Association of periOperative Registered Nurse, recommends that workers should not stand for more than 2 hours continuously or for more than 30% of the work day (Waters, 2015). If the amount of standing exceeds this, fatigue-reducing interventions, such as anti-fatigue mats, specially designed footstools, sit-stand stools or chairs, or supportive footwear should be implemented. The ILO or International Labor Organization published guidelines in 2011 to reduce health risks associated with prolonged standing at work. When a job requires an employee to stand for *any* amount of time, a chair or stool must be provided for the worker to take regular breaks (Waters, 2015). The ILO also suggests that work surface heights should be adjustable, so the employee can adjust the height of the table for

their specific height. This will allow for the arms to not be suspended in awkward or uncomfortable positions (Waters, 2015). The effectiveness of varied solutions may differ, but it is important for OSH staff to assess which solution(s) best meet the needs of the employees in Sri Lanka.

A. Stretching

If workplace operations continue without appropriate breaks, stretching can help prevent muscle imbalance and decrease the risk of MSD. Stretching is the opposite direction by which the operator works is the most effective. This can include rotation and side bending. A picture of some appropriate stretches is seen below:

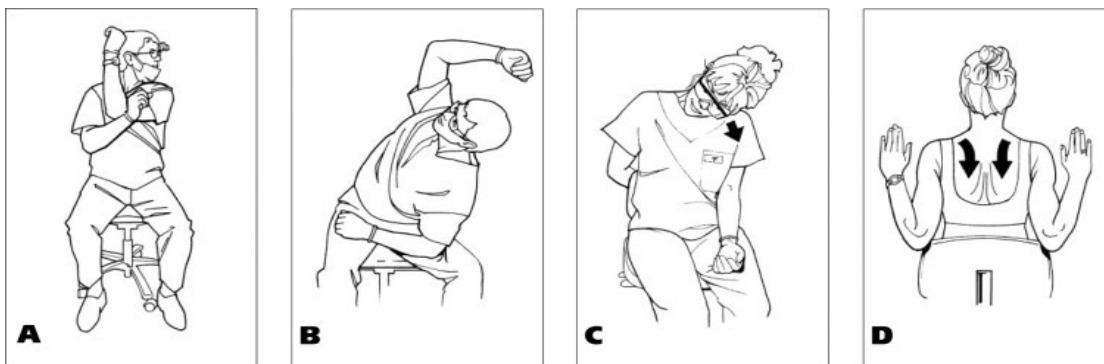

Figure 4: Panel A is a neck and shoulder stretch. This stretch should be done with the elbow at shoulder height at a 90° angle. The arm is pulled across the front of the body by the opposite arm. The head should rotate to look over the bent arm's shoulder. This stretch should be held for 2-4 breathing cycles and then repeated on the opposite arm.

Panel B is shoulder and back stretch. The knees should be placed farther than shoulder width apart, then the torso bends to the left side, and the body weight is placed on the left elbow of the left knee. The right arm is then stretched overhead, and the head turns toward the ceiling. This stretch should be held for 2-4 breathing cycles and then repeated on the opposite arm.

Panel C is an upper trapezius or upper back stretch. The right arm is placed behind the chair, while the left ear is brought toward the left armpit. This stretch should be held for 2-4 breathing cycles and then repeated on the opposite arm.

Panel D is a back stretch. The chest is lifted upwards and the arms are placed at the sides of the body with the fingers pointing upward. The palms face forward as the shoulders are rolled back and down. The shoulder blades should be squeezed together during the rotation. This stretch should be held for 1 breathing cycle and then repeated on the opposite arm.

The positive benefits of stretching include: increase in blood flow to the muscles, increase in range of motion, improved relaxation on the CNS (central nervous system), and identification of potential injuries. While a person is stretching or sitting, it is important to maintain a low back curve as seen in the picture below. This posture can severely lower the incidence of back pain.

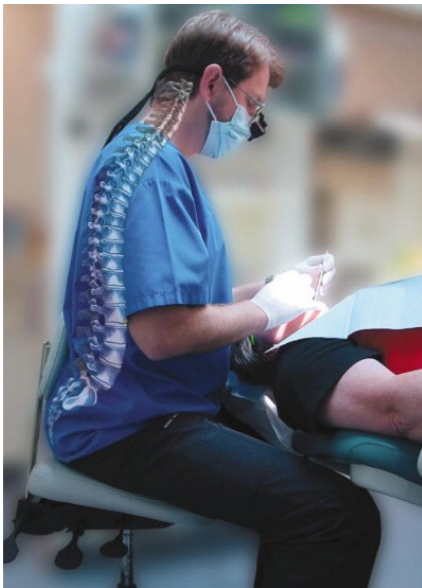

Figure 5: The doctor is displaying the proper sitting posture when sitting in a perch chair.

B. Perch Chairs

If chairs are implemented into the workplace, below are directions regarding how to properly adjust a perch chair:

1. "Tilt the seat angle slightly forward, 5-15 degrees to increase the low back curve. This will place the hips slightly higher than the knees and increase the hip angle to greater than 90°, which may allow for closer positioning to the table. Chairs without the tilt feature can be retrofitted with an ergonomic wedge-shaped cushion."

2. “Sit close to the table and position knees under the table. This can be facilitated by tilting the seat. For some operators, this positioning may cause shoulder elevation or arm abduction. In such cases, a different working position should be assumed.”
3. “Consider using a saddle-style operator stool that promotes the natural low back curve by increasing the hip angle to approximately 130°. Using this type of stool may allow the operator to be closer to the table.”
4. “Adjust the chair so the hips are slightly higher than the knees and distribute the weight evenly by placing the feet firmly on the floor. The forward edge of the chair should not compress the backs of the thighs.”
5. “Use the lumbar support of the chair as much as possible by adjusting the lumbar support forward to contact the back.”
6. “Stabilize the low back curve by contracting the transverse abdominal muscles. To do this while sitting, sit tall with a slight curve in the low back, exhale, pull the navel toward the spine without letting the curve flatten. Continue breathing while holding the contraction for 1 breath cycle. Repeat 5 times. Strive to maintain this stabilization regularly throughout the workday.”
7. “Pivot forward from the hips, not the waist. Stabilize the low back curve by performing the previous exercise before pivoting forward.” (Valachi, 2003).

Benefits of perch chairs

A study by Irving in 1982, took a survey of surgeons who stood for long hours at a time during procedures. Irving concluded that low back discomfort decreased when a pelvic-tilt chair was used to alternate between sitting and standing (Irving, 1982). Another study by Rempel in 2007, demonstrated the benefit of curved seat pans. Rempel’s findings concluded that height adjustable chairs with a curved

seat pan reduced the amount of neck and shoulder pain among sewing machine operators (Rempel, 2007). A picture of a curved seat pan is shown below:



Figure 6: The 2-part curved seat pan design prompts forward leaning and increases the thigh torso angle. This design preserves lumbar lordosis, or the curving of the lower back.

The graph below shows the crude pain score and the adjusted pain score when utilizing a flat seat pan or a curved seat pan for 4 months. It can be observed that the employees had significantly less pain when sitting in a curved seat pan chair.

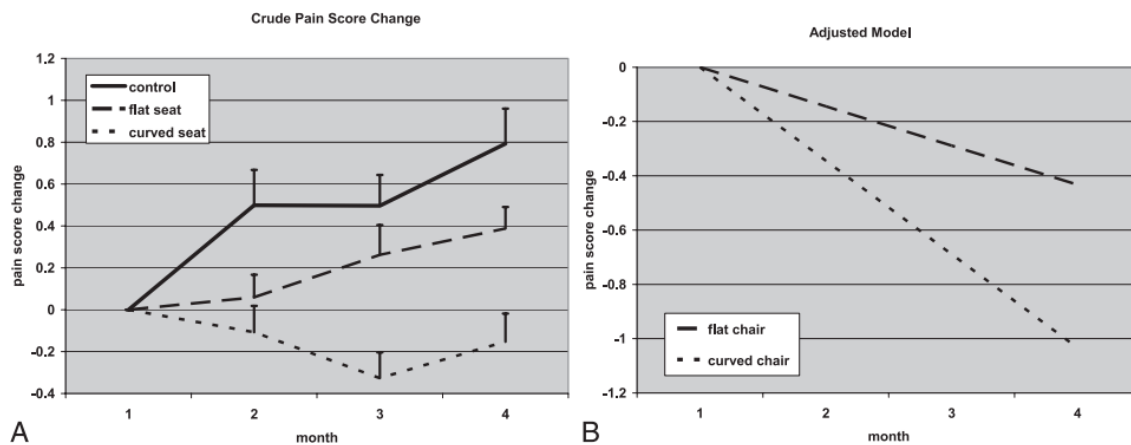

Figure 7: The left-hand graph shows the crude pain score changes between months 1 and 4. The right-hand graph shows the pain score slope for flat and curved seat pan chairs compared to the control group (Rempel, 2007).

The table below shows a model for employers to gauge how much standing is appropriate based on predictive health risks.

TABLE 1
The Stoplight Model for Standing Work Guidelines¹

Green = safe stress No action required	Amber = some risk Action recommended	Red = health risk Direct action required
Not more than 1 hour of continuous standing and not more than 4 hours of standing in total	More than 1 hour of continuous standing or more than 4 hours of standing in total	More than 1 hour of continuous standing and more than 4 hours of standing in total

I. Kibbe JJ, Kriibe NE, Geuze L. Werkpakket Beter! [Practical Tools for Ergonomic Preventive Interventions in Hospitals]. Utrecht, the Netherlands: Sectorfonds Zorg en Welzijn; 2003:9-12.

Figure 8: The Green zone merits no intervention to prevent health risks when continuous standing is less than one hour. The Amber zone merits intervention to prevent

further health impacts because continuous standing is greater than 1 hour. The Red zone merits major intervention as health risks are dangerous to the worker's health as continuous standing has occurred for greater than 1 hour and for >4 hours/shift (Kibbe, 2003).

C. Sit-Stand Workstations

Benefits of postural variability

A study done by Davis in 2014, looked at the benefits of postural variability in a workstation. Davis concluded that sit-stand tables decreased short-term discomfort by the end of the workday. Additionally, sit-stand tables did not appear to have a negative impact on productivity, when compared to sitting all day. This conclusion also applies to standing all day as the literature supported most importantly the benefits of postural variability (Davis, 2014).

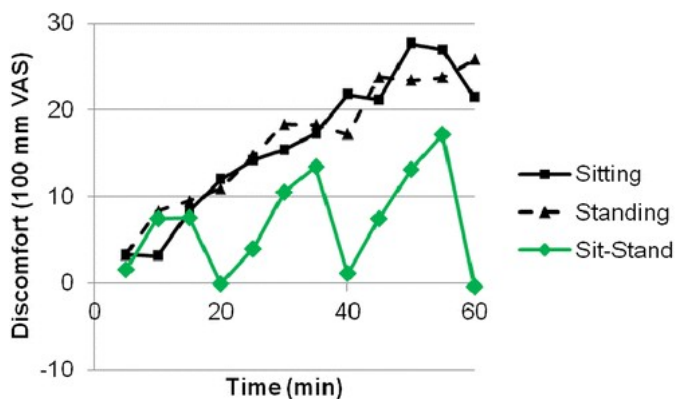

Figure 9: The sit-stand workstation presents more significant decreases in discomfort for employees with 20-minute interval recovery windows (Karakolis, 2016).

There is indeed no silver bullet to eliminate ergonomic risks and occupational fatigue with repetitive motions but sit-stand workstations have proven to decrease the amount of lower limb discomfort. Sit-stand workstations have also proven to improve venous return in the body and overall vascular health (Antle, 2015).

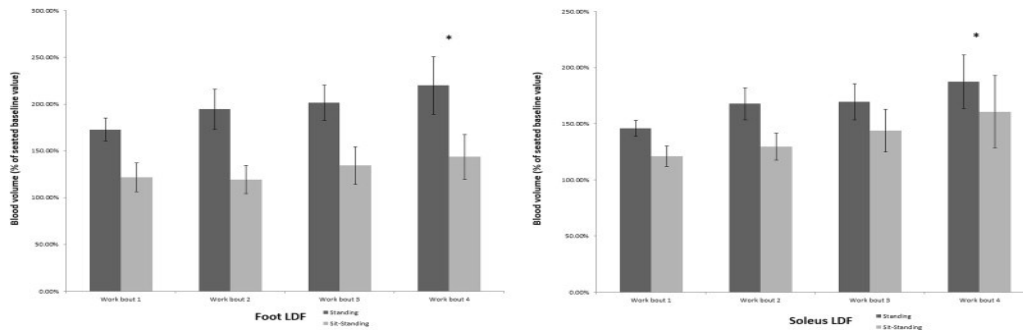

Figure 10: The left-hand graph shows the venous blood volume in the foot, while the right-hand graph

shows the venous blood volume in the soleus (Antle, 2015).

Three studies found that the lower amount of blood pooling in the lower limbs and lower blood pressure can lower the strain on the lower limb tissues and decrease the risk of developing peripheral vascular disorders (Kroeger, 2004; Tuchsén, 2005; Raffetto, 2008). This is particularly important for women in Sri Lanka as one of the chief complaints after work was lower limb pain that prevented the women from walking.

Another study found a significant decrease in overall lower limb pain due utilizing sit-stand workstations compared to standing. These results support using sit-stand workstations in industrial settings (Antle, 2015). The graph below displays the overall lower limb discomfort for workers. A pain score of 0-3 indicates light discomfort, a pain score of 4-6 indicates medium to strong discomfort, and a

pain score of 7-10 indicates disrupting discomfort to work pace/activity to unbearable discomfort.

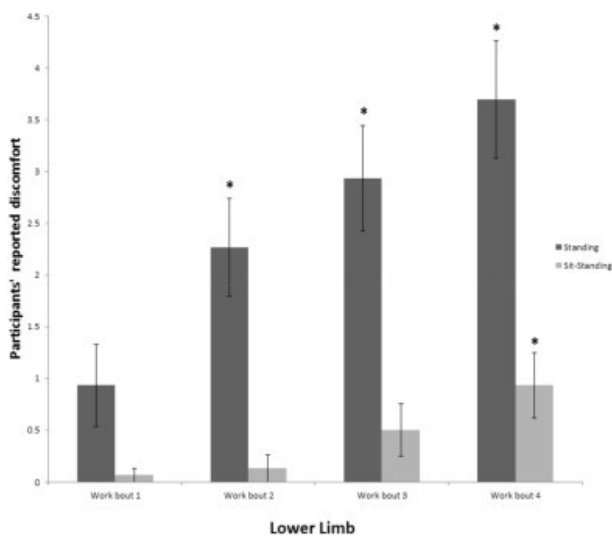

Figure 11: The graph shows workers that had more pain in the lower limbs due to long-term standing compared to sit-standing (Antle, 2015).

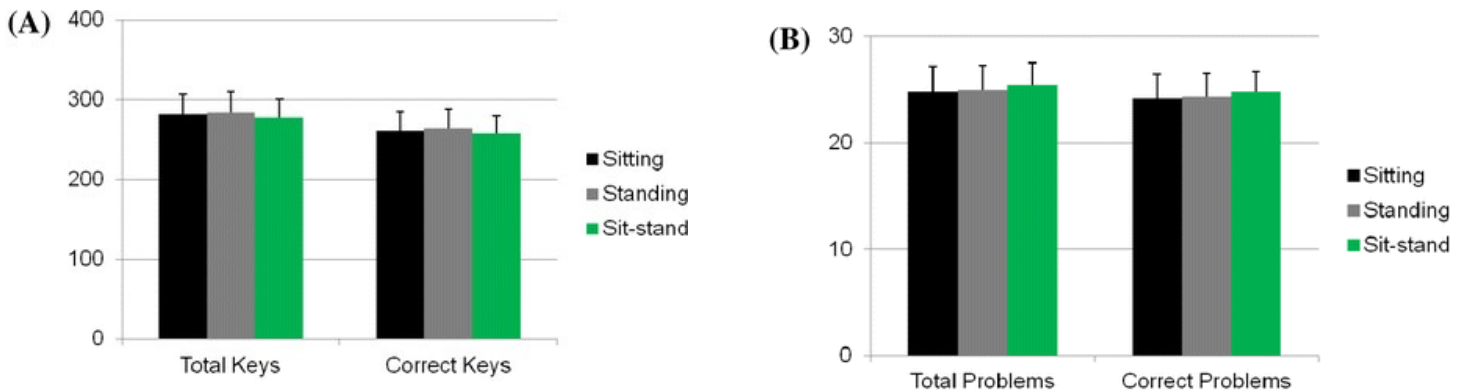

Figure 12: Graph A shows the productivity of typing tasks as measured by keystrokes per minute and the total number of correct keystrokes hit per minute. Graph B shows the productivity of mousing tasks as measured by the total problems completed per minute and the number of correct problems achieved per minute. The y-axis is minutes.

Another study by Karakolis in 2016, indicated that the productivity of office workers for typing and mousing did not decline from using sit-stand workstations, compare to long-term standing or long-term sitting (Karakolis, 2016). This is significant because the employers in Sri Lanka decided to change all the sewing stations to standing and moving, in order to improve productivity. This study is also relevant to the workers in Sri Lanka because office work, similar to sewing, is a repetitive task that requires a high level of speed and accuracy. It was also noted that alternating between sitting and standing in a 15:5 min ratio over an hour, showed the potential to reduce back discomfort. One of the drawbacks to the study, was that reduced pain was based on a subjective measure, not a physiological or biomechanical metric.

D. Compression stockings

Compression stockings can also be worn to help with prolonged occupational standing. A study done by McCulloch in 2002, confirmed that support hose reduces symptoms of CVI and overall leg pain

(Waters, 2015). Below is a picture of an example of compression socks, which are similar to compression stockings.



Figure 13: Rymora is an ergonomically favorable compression sock brand.

The drawback to utilizing support hose is that the selection of hose can depend on the preexisting CVI conditions of the worker. Employees with preexisting health conditions need to also be evaluated by a medical professional, which may be harder in remote areas where medical care is difficult to access. A study done by Partsch in 2004, evaluated the impact of support stockings on edema due to prolonged standing. The results of this study indicated that nighttime edema was significantly reduced due to the use of compression stockings (Waters, 2015). Some additional drawbacks of compression stockings noted in this study, were that the stockings may also be expensive.

E. Floor mats, shoes, and shoe inserts

Another solution for prolonged standing is utilizing floor mats. One study by Cham in 2001, discovered that floor mats with increased elasticity, decreased energy absorption from the user, and increased stiffness, tended to lead to less discomfort and fatigue from long-term standing (Cham, 2001). A more recent study done by Lin in 2012, created a study that mirrored standing for 4 hours. Lin discovered that the floor type and the shoe condition lowered the overall discomfort in the employees' feet. These changes and improvements were noted after the 3rd hour of exposure to prolonged standing. Another similar study by Redfern and Cham, concluded that changes and improvements to pain were noticeable during the 1st hour of work (Redfern, 2000). The authors explained the discrepancy due to



differences in methodology, such as measured duration of prolonged standing. This is significant because the women in Sri Lanka hardly wear shoes, and if they do, the shoes are very unsupportive.

Figure 14: Industrial floor mats are used to decrease lower limb and pain back for workers.

Appendix A shows a picture of a woman in Sri Lanka with cloth shoes and a small floor mat. It is evident that the combination of these two controls is not enough to decrease the women's overall pain. Below is a more appropriate version of a floor mat for factory workers.

F. More breaks

Another administrative control solution, would be to implement more breaks throughout the workday. The diagram below shows the appropriate number of breaks according to the ILO:

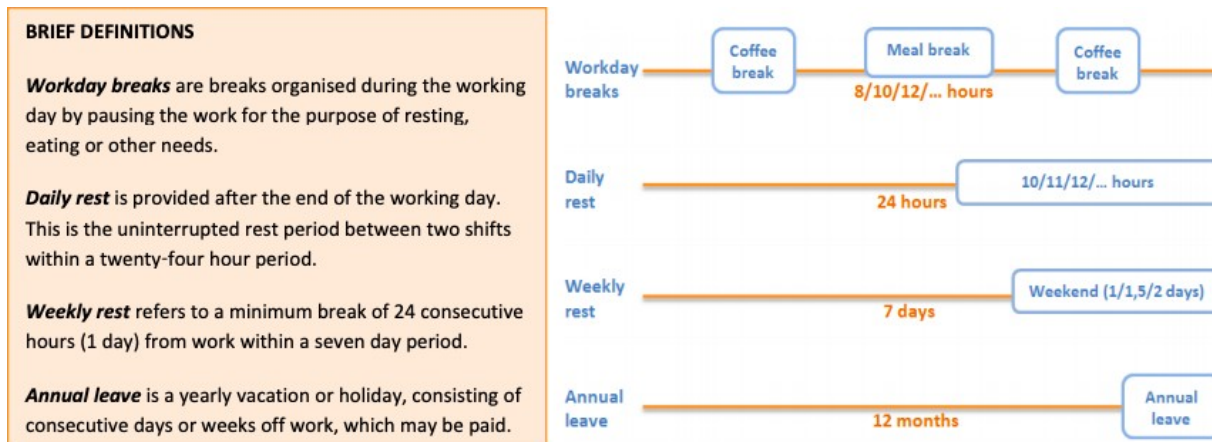

Figure 15: The ILO fact sheet describes the appropriate number of breaks workers should have during the workday.

According to the ILO coffee or tea breaks should be about 10-30 minutes and meal breaks should be 30-120 minutes. It is in the best interest of the employees to have paid breaks so that the employees

are encouraged to take time to rest. This is especially important in Sri Lanka factories because the production targets are so high that women work non-stop to receive the production incentives. The women therefore do not drink water so they do not have to go to the bathroom and miss time working. There should also be appropriate rest facilities, such as a break room with chairs for long-term standing workers or an exercise room for long-term sitting employees. Separate facilities from the factory are key to limit the employees' exposure to noise, chemicals, and other hazardous exposures while on their break (ILO, 2015). Additionally, the Sri Lanka Factories Ordinance, chapter 4 of the Occupational Safety & Health and Payment of Workmen's Compensation, states: "a woman or young person shall not be employed continuously for a spell of more than four and a half hours without an interval of at least half an hour for a meal or rest, so, however, that in respect of regular day time workers, one such interval shall be allowed to commence between the hours of eleven o'clock in the morning and one o'clock in the afternoon, and that where an interval of not less than ten minutes is allowed in the course of a spell, the spell may be increased to five hours." (Labour Department, 1950).

G. Healthy lunch

Another concern raised by the CCC was the lack of an appropriately nutritious lunch. If women are expected to work for an 8-hour shift, a proper meal should be provided from the company. Nutritious meals should be high in vegetables, protein, and carbohydrates. The picture below shows appropriate



portions of each food group according to the UK (Eufic, 2009).

Figure 16: Above the picture displays the appropriate amount of each food group to

consume to achieve optimal nutrition. The largest basis of the meal should consist of vegetables and grains.

Traditional Sri Lankan meals that may be easy and nutritious to make at the factory could be *kottu roti*, which is a stir-fry of vegetables, bread, meat, spices, garlic, ginger, and soya sauce. Another traditional meal is *lamprais* which consists of boiled eggs, eggplant, beef balls, sambol, spices, rice, and is then wrapped in a banana leaf. One additional meal that is healthy and full of nutrition is *dhal curry* which is made of red lentils, coconut milk, onions, tomatoes, green chilies, and spices (Sunder, 2018).

From my work in Ethiopia, the most cost-effective way to make food for a large manufacturing plant was to start from the same raw ingredients and have three to four rotating meals that use these starting ingredients. For example, injera is the base for every meal, which is made from teff flour which is high in protein. The base ingredients for the three meals are onions, tomatoes, garlic, lentils, red pepper, and garbanzo beans. The meals are nutritious and sustainable for the long workday.

Conclusions & Future Advice

Although employers in Sri Lanka were hopeful that the Kaizen adopted ‘dancing work’ system may create more productivity, quality and profitability from their products, the benefits to cellular manufacturing and lean production may not be worth the shift. The resulting human health consequences and overwhelming amount of literature indicate the health impacts of lean production on workers. The health impacts of prolonged standing include, low back pain, cardiovascular issues, fatigue, and negative pregnancy outcomes. Some of the proposed solutions for the Sri Lanka factories include, stretching, perch chairs, sit-stand workstations, compression stockings, floor mats, more frequent work breaks, and providing a healthy lunch. Overall, there is many documented health impacts associated with cellular manufacturing. It is clearly in the best interest of the Sri Lanka employers to invest in the health of their workers to ensure the health of their companies’ futures.

Citations

- Antle D.M. et al. “Comparing standing posture and use of a sit-stand stool: Analysis of vascular, muscular and discomfort outcomes during simulated industrial work.” *International Journal of Industrial Ergonomics*, vol. 45, 2015, p. 98-106. doi:10.1016/j.ergon.2014.12.009
- Buman M.P. et al. “An Intervention to reduce sitting and increase light-intensity physical activity at work: Design and rationale of the ‘Stand & Move at Work’ group randomized trial.” *Contemporary Clinical Trials*, vol. 53, 2017, p. 11-19. doi:10.1016/j.cct.2016.12.008
- Canadian Centre for Occupational Health and Safety. “OSH Answers Fact Sheet” *Government of Canada*, 4 July 2016, https://www.ccohs.ca/oshanswers/ergonomics/standing/standing_basic.html
- Cham R et al. “Effect of flooring on standing comfort and fatigue.” *Human Factors*, vol. 43. No. 3, 2001, p. 381–391. doi:10.1518/001872001775898205
- Chem J.C. et al. “A Kaisen Based Approach for Cellular Manufacturing System Design: A Case Study.” *Journal of Technology Studies*, vol. 27, 2001, p. 19-27. doi:10.21061/jots.v27i2.a.3
- Davis K.G. et al. “Postural Variability: An Effective Way to Reduce Musculoskeletal Discomfort in Office Work.” *Human Factors*, vol. 56 no. 7, 2014, p. 1249-61. doi:10.1177/0018720814528003}
- EUFIC “Food-based dietary guidelines in Europe”, 2009, <https://www.eufic.org/en/healthy-living/article/food-based-dietary-guidelines-in-europe>
- Irving G. “A standing/sitting pelvic tilt chair--new hope for back-weary surgeons?” *South African Medical Journal*, vol. 82. No. 2, 1992, p. 131–132.
- Jolkkonen et al. “Rest Periods: Definitions and Dimensions” *International Labor Organization*, 2015, https://www.ilo.org/wcmsp5/groups/public/---ed_protect/---protrav/---travail/documents/publication/wcms_491374.pdf
- Karakolis T et al. “A Comparison of trunk biomechanics, musculoskeletal discomfort and productivity during simulated sit-stand office work.” *Ergonomics*, vol. 59 no. 10, 2016, p. 1275-1287. doi:10.1080/00140139.2016.1146343
- Kibbe J.J. et al. “Workpakket Beter! [Practical Tools for Ergonomics Prevention Interventions in Hospitals].” *Utrecht, the Netherlands: Sectorfondsen Zorg en Welzijn*, 2003, p. 9-12.
- Kroeger K et al. “Risk factors for varicose veins.” *International Angiology*, vol.23. No.1, 2004, p. 29-34.

- Labour Department “Occupational safety & Health and Payment of Workmen’s Compensation”
Factories Ordinance, 1950,
http://www.labourdept.gov.lk/images/PDF_upload/chapter04/1_factories_ordinance_i.pdf
- Landsbergis P.A. et al. “The Impact of Lean Production and Related New Systems of Work Organization on Worker Health.” *Journal of Occupational Health Psychology*, vol. 4. No. 2, 1999, p.108-130. doi:10.1037/1076-8998.4.2.108
- Lin Y.H. et al. “Influence of shoe/floor conditions on lower leg circumference and subjective discomfort during prolonged standing.” *Applied Ergonomics*, vol. 43, 2012, p. 965–970.
- McCulloch J. “Health risks associated with prolonged standing.” *Work*, vol. 19. no.2, 2002, p.201–205.
- Nelson-Wong E et al. “Gluteus medius muscle activation patterns as a predictor of low back pain during standing.” *Clinical Biomechanics*, vol. 23. No. 5, 2008, p.545–553.
 doi:10.1016/j.clinbiomech.2008.01.002
- Pan G. “A Quantitative Analysis of Cellular Manufacturing in Apparel Industry by Using Simulation.” *Journal of Industrial Engineering and Management*, vol. 7. No. 5 2014, p. 1385-1396.
 doi:10.3926/jiem.1184
- Partsch H et al. “Compression stockings reduce occupational leg swelling.” *Dermatologic Surgery*, vol. 30. No. 5, 2004, p.737–743.
- Paul J.A. et al. “Standing working posture compared in pregnant and non-pregnant conditions.” *Ergonomics*, vol. 37. No.9, 1994, p.1563–1575. doi:10.1080/00140139408964934
- Raffetto J.D. et al. “Mechanisms of varicose vein formation: valve dysfunction and wall dilation.” *Phlebology*, vol. 23. no. 2, 2008, p. 85-98
- Redfern M.S. et al. “The influence of flooring on standing comfort and fatigue.” *AIHAJ - American Industrial Hygiene Association*, vol. 61. No. 5, 2000, p. 700–708. doi:
 10.1080/15298660008984580
- Rempel D.M. et al. “A Randomized Controlled Trial Evaluating the Effects of New Task Chairs on Shoulder and Neck Pain Among Sewing Machine Operators.” *SPINE*, vol. 32. No. 9, 2007, p. 931-938. doi:10.1097/01.brs.0000261028.88020.fc

- Schnall, P. L. et al. "A longitudinal study of job strain and ambulatory blood pressure: Results from a three-year follow-up." *Psychosomatic Medicine*, vol. 60., 1998, p. 697- 706.
<https://www.ncbi.nlm.nih.gov/pubmed/9847028>
- Sudoł-Szopińska I et al. "Work-related chronic venous disease in office and bakery workers." *Occupational Ergonomics*, vol. 7. No. 2, 2007, p. 125–137.
- Sunder, Kalpana. "Top 10 foods to try in Sri Lanka" *BBC good food*, 2018,
<https://www.bbcgoodfood.com/howto/guide/top-10-foods-try-sri-lanka>
- Teitelman A.M. et al. "Effect of maternal work activity on preterm birth and low birth weight." *American Journal of Epidemiology*, vol. 131. No. 1, 1990, p.104–113.
- The Guardian. "Sri Lanka needs to regain its trade concessions but workers must benefit", 2018,
<https://www.theguardian.com/global-development/poverty-matters/2011/jan/20/sri-lanka-free-trade-zones>
- Tuchsen F et al. "Prolonged standing at work and hospitalization due to varicose veins: a 12-year prospective study of the Danish population." *Occup. Environ. Med.*, vol. 62. No.12, 2005, p. 847-850.
- Valachi B. et al. "Preventing musculoskeletal disorders in clinical dentistry: Strategies to address the mechanisms leading to musculoskeletal disorders." *Journal of the American Dental Association*, vol. 134. no. 12, p.1604-1612. doi:10.14219/jada.archive.2003.0106
- Waters T.R. et al. "Evidence of Health Risks Associated with Prolonged Standing at Work and Intervention Effectiveness." *Rehabilitation Nursing*, vol. 40. No. 3, 2015, p.148–165.
doi:10.1002/rnj.166.
- Womack J.P. et al. *The Machine that Changed the World*. Rawson Associates, 1990.

Appendix A

Standing working prolong time (Dancing Module)

E.G (One simple operation)

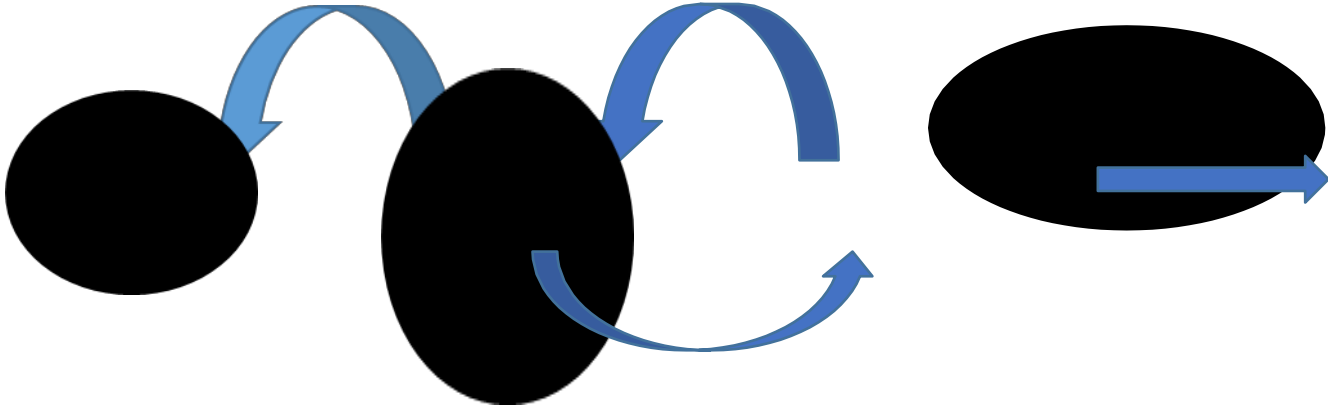

Simple module

Time - M / 1 -

Total - 12 minutes

Posture - 100 %

Frequent - Quick
+++)

Rest - Only Tea /

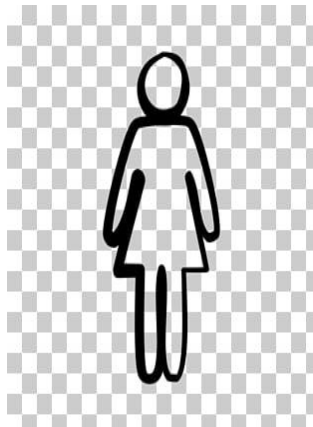

M / 3 Minutes

(3 machines But 04 Operations)

Standing

moving (Every 03 Minutes / Depend on the module and

Lunch Break



Line Input

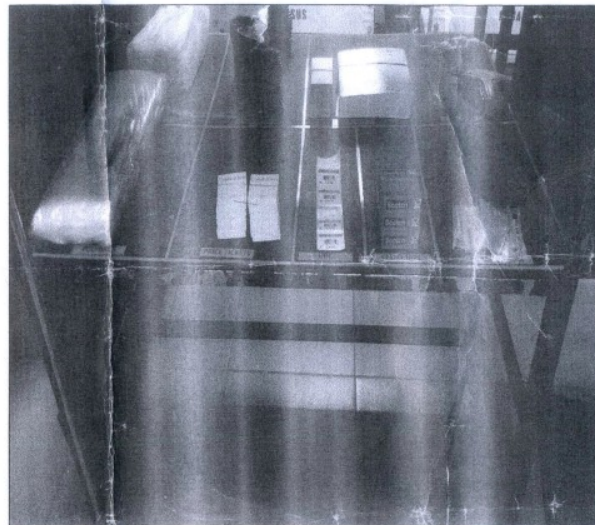

Packing Trims